

REV	DESCRIPTION	DESIGN	DATE
A0	Release	吴丹平	2016.11.11

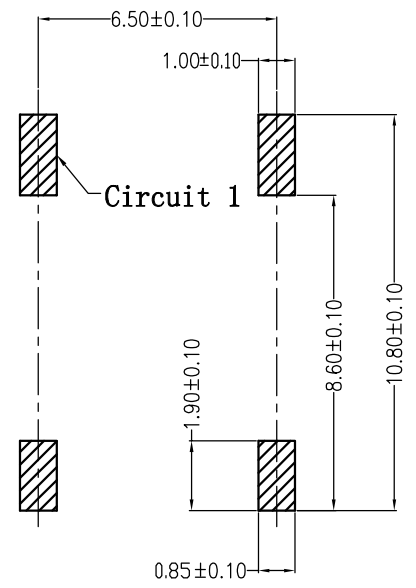
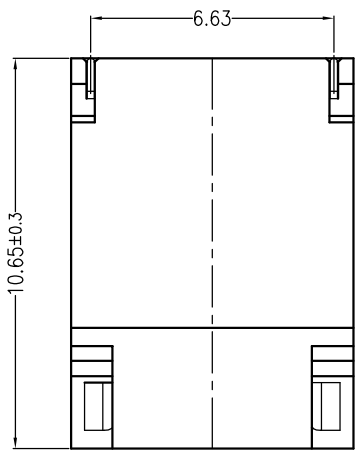
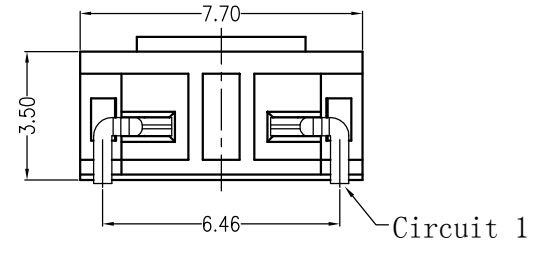
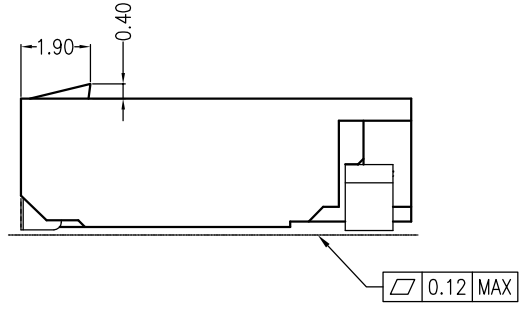
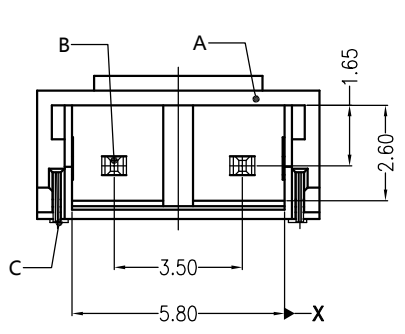

主要技术参数 Main Specifications

- 线数 (Poles): 02
- 接触电阻 (Contact resistance): $\leq 10m\Omega$
- 绝缘电阻 (Insulation resistance): $\geq 1000M\Omega$
- 额定电压 (Rated voltage): 1400V AC DC
- 额定电流 (Rated current): 1.0A AC DC
- 耐电压 (Withstand Voltage): 3800V AC/minute
- 温度范围 (Temperature Range): $-25^{\circ}C \sim +105^{\circ}C$

ORDER INFORMATION:

A3502AWR-02-F3MA-R

PART No.:		PACKAGING:	
No. OF CIRCUITS:		R=REEL	
02		P=PE	
PLASTIC MATERIAL:		PLATING:	
F3M=LCP (BEIGE)		A=Sn	

SUGGESTED PCB LAYOUT
(COMPONENT SIDE)

C	SOLDER TAB	2 PCS	PhosphorBronze	Sn-plated
B	CONTACT	2 PCS	PhosphorBronze	Sn-plated
A	PEDESTAL	1 PCS	LCP	UL 94V-0, COLOR:BEIGE
ITEM	COMPONENT	Q'TY	MATERIAL	FINISH

JKUN 温州健坤接插件有限公司 WENZHOU JKUN CONNECTOR CO.,LTD.		TITLE: - 3.5mmPITCH 90°WAFER SMT TYPE	
X.±0.5	X.±5'	USE:	PART NO.:
.X±0.3	.X±2'	CUSTOMER	A3502AWR-02-F3MA-R
.XX±0.25	.XX±1'	APPD:	DWG NO.:
--	--	邵敬和	JKUN-GCCP-0567
UNITS: mm		CHKD:	SCALE
DR: 蒋建银		田峰	SHEET
			1 : 1
			1 / 1

客户料号:

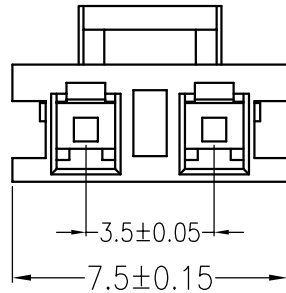
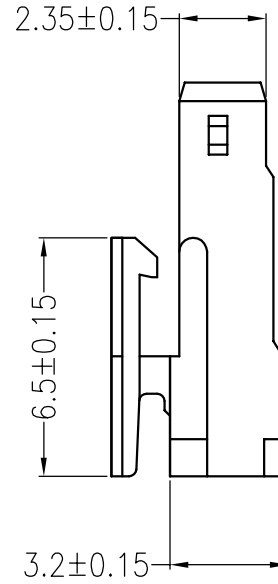
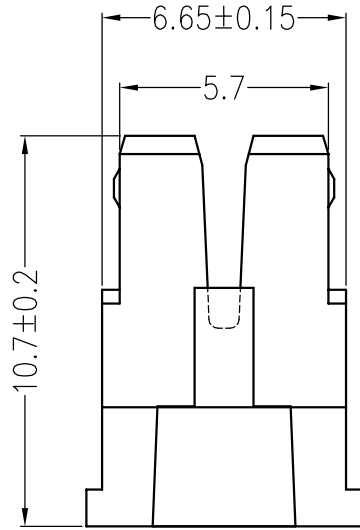

主要技术参数 Main Specifications

线 数 (Poles): 02
 接触电阻 (Contact resistance): $\leq 10m\Omega$
 绝缘电阻 (Insulation resistance): $\geq 500M\Omega$
 额定电压 (Rated voltage): 250V AC DC
 额定电流 (Rated current): 1.0A AC DC
 耐电压 (Withstand Voltage): 3800V AC/minute
 温度范围 (Temperature Range): $-25^{\circ}C \sim +85^{\circ}C$

ORDER INFORMATION:

A3502Y-02-A5W-P	
PART No.:	PACKAGING: R-REEL P-PE
No. OF CIRCUITS: 02	PLASTIC MATERIAL: A5W=PA66 (WHITE)

JKUN 温州健坤接插件有限公司
WENZHOU JKUN CONNECTOR CO., LTD.

APPROVED BY

邵敬和

CHECKED BY

伏何

DRAWN BY

吴丹平

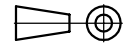

DATE

2016.07.25

UNIT

mm

SCALE

FULL

SHEET

1/1

TOLERANCE

X.X ±0.30

X.XX ±0.20

X.XXX ±0.10

ANGLE

X° ±3.0°

REV

A/0

EC#. NO

REVISION RECORD

NAME

吴丹平

DATE

2016.07.25

NO.

DESCRIPTION

QTY

MATERIAL

PLATING/COLOR

White

Insulator

1

PA66

DwgNo. JKUN/GCCP-0568